



 Sumitomo Heavy Industries, Ltd.

MANUAL NUMBER: CD32ZZ-064D

DATE: JUNE 9 / 2003

TECHNICAL INSTRUCTION

RDK-408D 4K COLD HEAD

For Service Personnel Only

***Sumitomo Heavy Industries, Ltd.
Cryogenics Division***

***2-1-1 Yato-cho, Nishitokyo-City,
Tokyo 188-8585, Japan***

TEL: +81-424-68-4240

FAX: +81-424-68-4219

E-mail: cryo@shi.co.jp

URL: <http://www.shi.co.jp/cryopage>

TABLE OF CONTENTS

SECTION	ITEM	PAGE No.
	CROSS REFERANCE	1
1	GENERAL INFORMATION	2
1-1	SPECIFICATIONS	3
1-2	CONSTRUCTION	5
2	MAINTENANCE	7
	APPENDIX	
	DRAWINGS	
	REVISION CONTROL	

CROSS REFERENCE

Thoroughly read this manual and following manuals before using this equipment.

MANUAL NAME	MANUAL No.
OPERATION MANUAL SRDK Series CRYOCOOLER*	CD32ZZ-063
OPERATION MANUAL SRDK Series CRYOCOOLER* (for Outdoor used Compressor Unit)	CD32ZZ-076
TECHNICAL INSTRUCTION CSA-71A COMPRESSOR UNIT**	CD32ZZ-067
TECHNICAL INSTRUCTION CSW-71C COMPRESSOR UNIT**	CD32ZZ-068
TECHNICAL INSTRUCTION CSW-71D COMPRESSOR UNIT**	CD32ZZ-069
TECHNICAL INSTRUCTION CNA-61C OUTDOOR USED COMPRESSOR UNIT**	CD32ZZ-077
TECHNICAL INSTRUCTION CNA-61D OUTDOOR USED COMPRESSOR UNIT**	CD32ZZ-078

* See TECHNICAL INSTRUCTION of Compressor Unit used.

** See TECHNICAL INSTRUCTION of Compressor Unit used.

1 GENERAL INFORMATION

The RDK-408D Cold Head is a two-stage GM cycle cryo-refrigerator. The function of the Cold Head is to produce continuous closed-cycle refrigeration at temperatures, depending upon the heat load imposed, in the range of 25 K to 40 K for the first-stage cold station and in the range of 3.5 K to 4.2 K for the second-stage cold station.

The Cold Head has three major components: the drive unit; the cylinder; and the displacer-regenerator assembly, which is located inside the cylinder.

With newly developed rare earth regenerator material and with very unique structure, the model RDK-408D Cold Head has its 2nd stage refrigeration capacity of 1W at 4.2K.

Functionally, the high-pressure helium gas from the Compressor Unit will be supplied to the Cold Head through the helium gas supply connector. The supply gas will be passed into the displacer-regenerator assembly, come out through the displacer-regenerator assembly to the crankcase through the motor housing, and finally will be returned to the Compressor Unit through the helium gas return connector. The helium gas expansion in the displacer-regenerator assembly will be provided cooling condition for the first and second-stage cold stations.

1-1 SPECIFICATIONS

The specifications of the RDK-408D Cold Head are summarized in **Table 1.1**. **Figure 1.1** shows the outline view of Cold Head.

Table 1.1 RDK-408D COLD HEAD SPECIFICATION

Refrigeration Capacity First Stage Second Stage	31 / 37 W at 40 K (50 / 60 Hz) 1.0 W at 4.2 K (50 / 60 Hz)
Orientation	Any Capacity Loss: Max. 15%
Ambient Operating Temperature	5 to 28 deg.C (41 to 82.4 deg.F) 28 to 35 deg.C (82.4 to 95 deg.F) with 5% Capacity Loss
Helium Gas Pressure for Indoor Used Compressor Unit Static Operating (High Side)* for Outdoor Used Compressor Unit Static Operating (High Side)*	1.60 - 1.65 MPa at 20 deg.C (68 deg.F) (16.3 - 16.8 kgf/cm ² G, 232 - 239 psig) 2.10 - 2.30 MPa --- approx. (21.4 - 23.5 kgf/cm ² G, 304 - 333 psig) 1.60 - 1.70 MPa at 20 deg.C (68 deg.F) (16.3 - 17.3 kgf/cm ² G, 232 - 246 psig) 1.90 - 2.10 MPa --- approx. (19.4 - 21.4 kgf/cm ² G, 275 - 304 psig)
Pressure Relief Valve Setting	1.86 - 1.96 MPa (19.0 - 20.0 kgf/cm ² G, 270 - 284 psig)
Gas Supply Connector Gas Return Connector	1/2-inch Coupling 1/2-inch Coupling
Dimension Width Length Height	180 mm (7.09') 294 mm (11.58') 557 mm (21.93')
Weight	18.0 kg (39.6 LBS) --- approx.

* The operating pressure varies according to the heat load of cold head and temperature around the equipment.

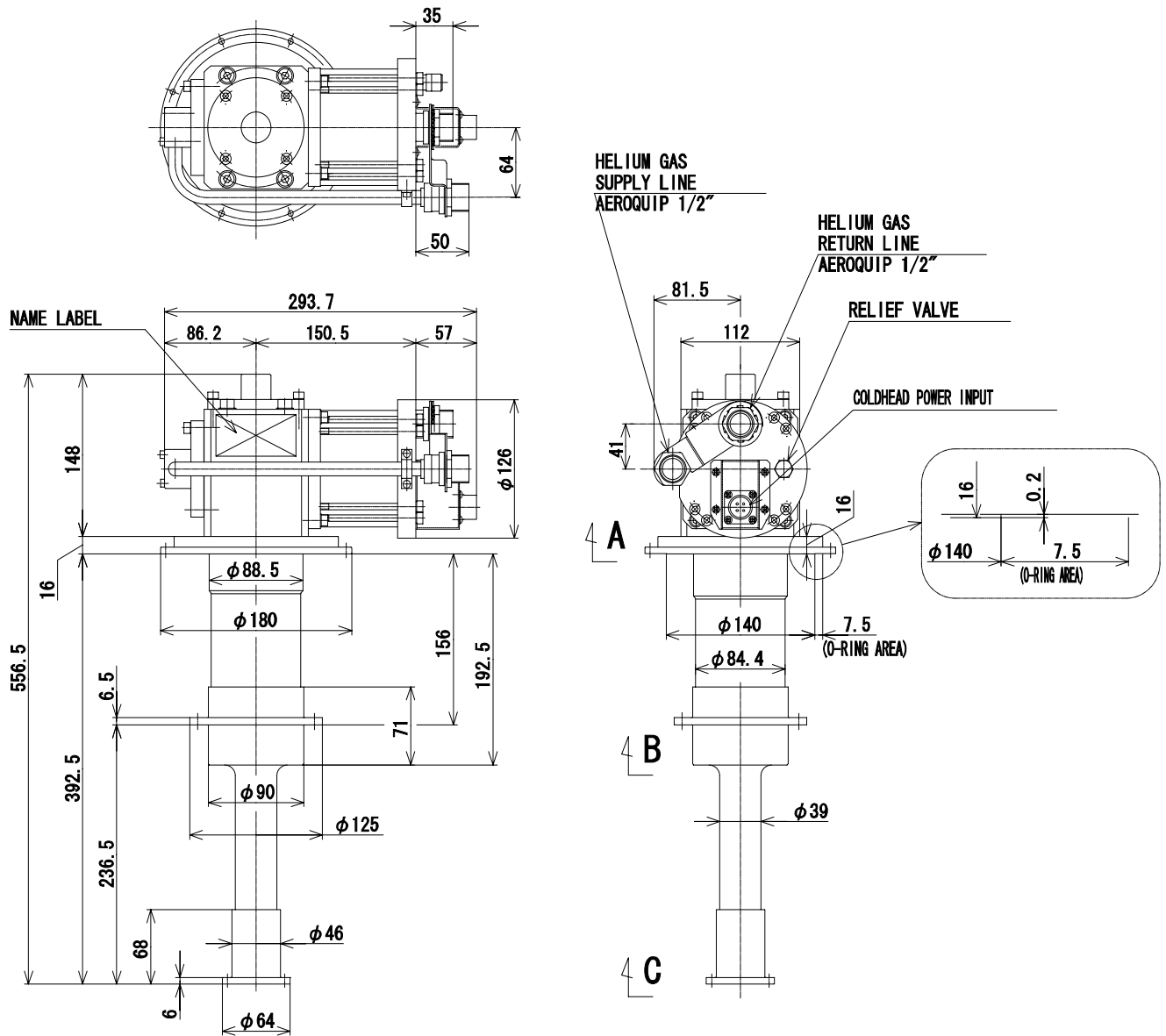

Figure 1.1 OUTLINE VIEW OF COLD HEAD MODEL RDK-408D

1-2 CONSTRUCTION

The cross section of the RDK-408D Cold Head is shown in **Figure 1.2**. It consists of a Cylinder, No. 1 Displacer, No. 2 Displacer, drive mechanism, and Cold Head Drive Motor. No. 1 Displacer is connected to the Scotch Yoke which can be driven by the Cold Head Drive Motor through the Crank with Bush so that the rotation of the Cold Head Drive Motor can be varied to reciprocating motion of Scotch Yoke and Displacers.

The Rotary Valve system is furnished to control the helium gas intake and exhaust timing. The Rotary Valve is also coupled to the Cold Head Drive Motor through Crank, so intake and exhaust operation is synchronized with the position of the Displacer.

The Displacer is a loose fit in the Cylinder except at the top and where it is equipped with a dynamic(sliding) seal to prevent leakage passed through the clearance between the Displacer and Cylinder.

The Displacers consist of regenerator material which cool the gas when passing downwards to the cold space and heats the gas when passing upwards from the cold space. Rear earth regenerator material is used in the 2nd stage Displacer to produce the cooling capacity at the temperature of 4.2K.

The pressure above and below the Displacer is the same except for small pressure drops across the regenerator when gas is flowing through it. Virtually no physical work is required to move the Displacer in the Cylinder. No work is done on the gas and the gas does no work on the Displacer. The pressure in the system is increased or decreased by operation of the inlet or outlet valves.

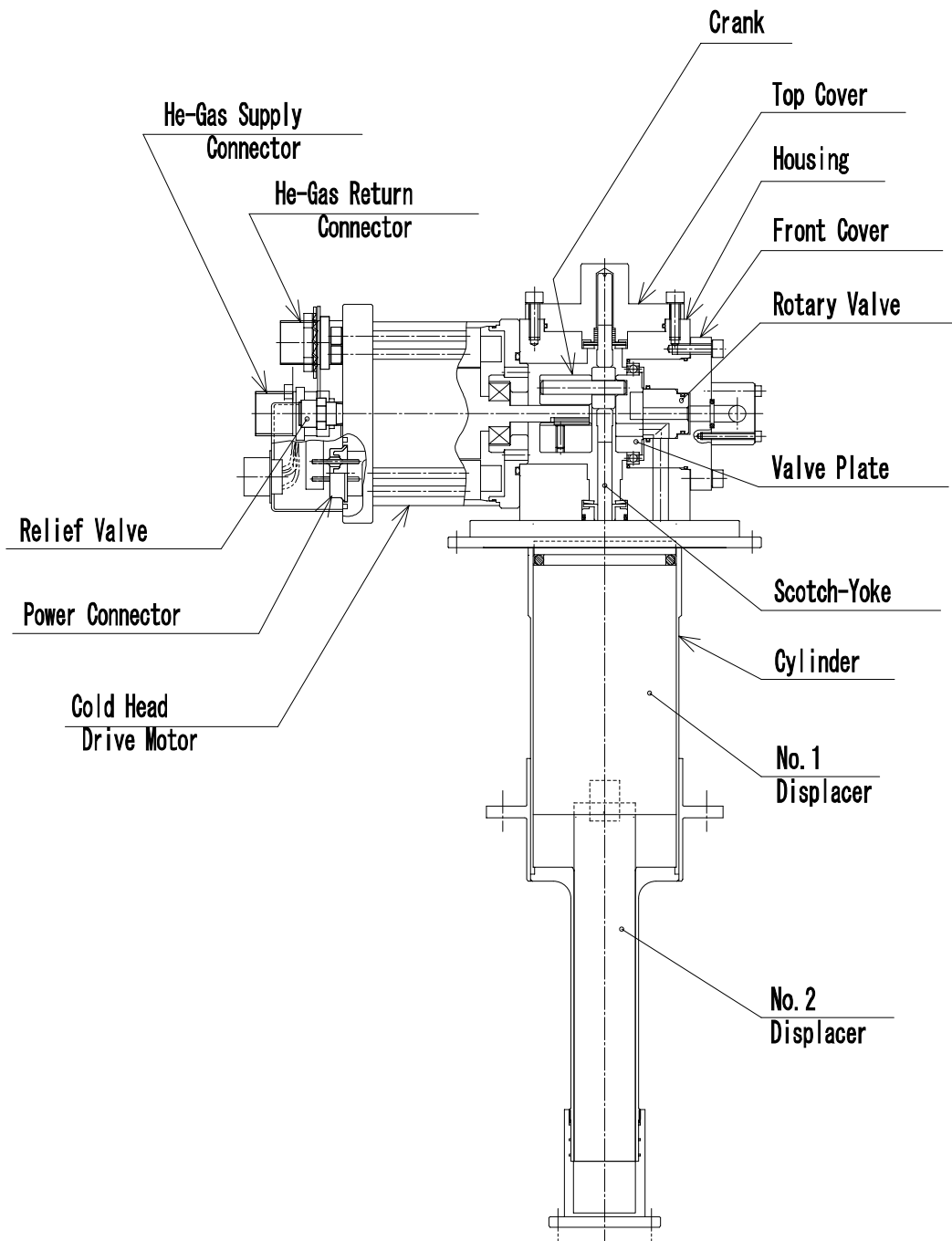

Figure 1.2 CROSS SECTION OF THE RDK-408D COLD HEAD

2 MAINTENANCE

The RDK-408D Cold Head is to be required to replace the sliding parts inside every 10,000 Hrs.

The maintenance work is not a User's maintenance. Replace the Cold Head completely at site and return it to Sumitomo Heavy Industries, Ltd. for refurbishment.

APPENDIX

DRAWINGS

No.	PART NAME
1	RDK-408D COLD HEAD

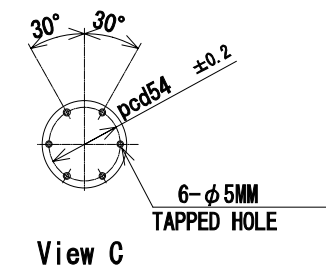
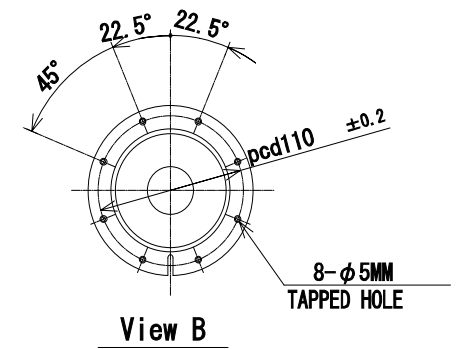
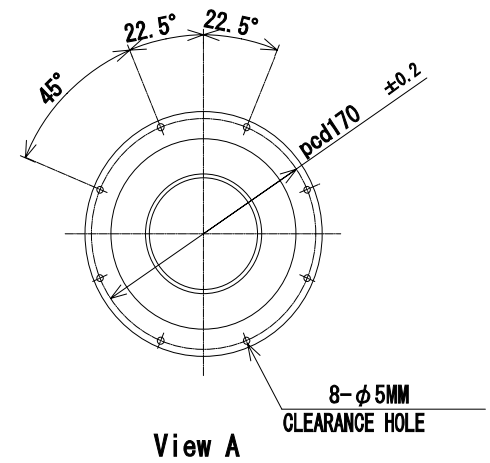
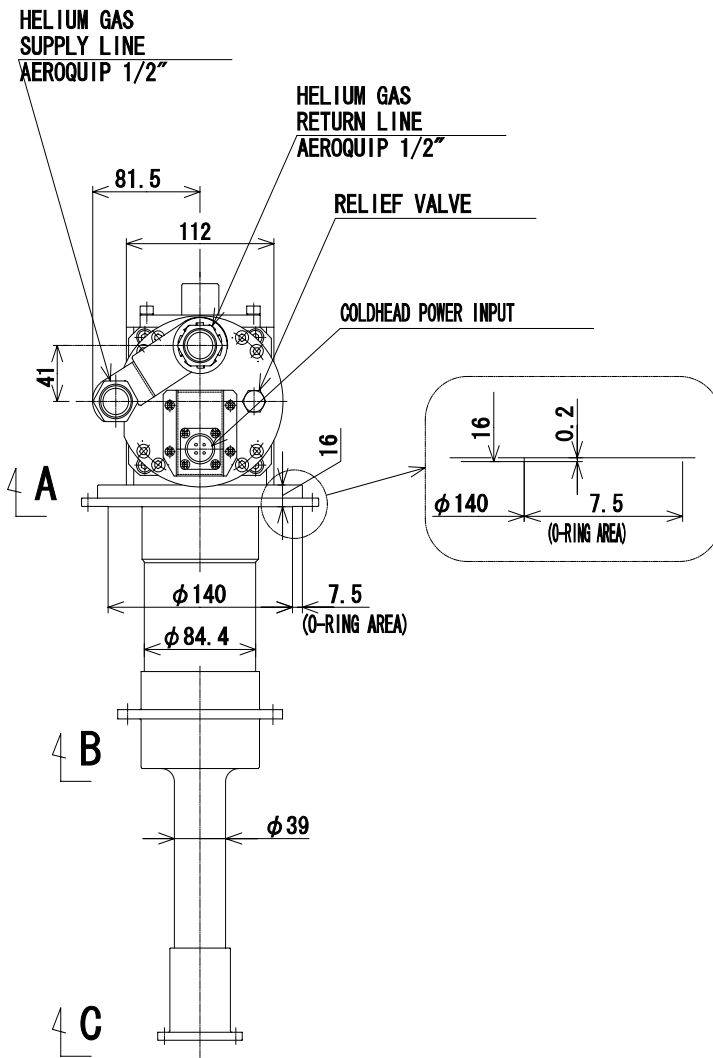
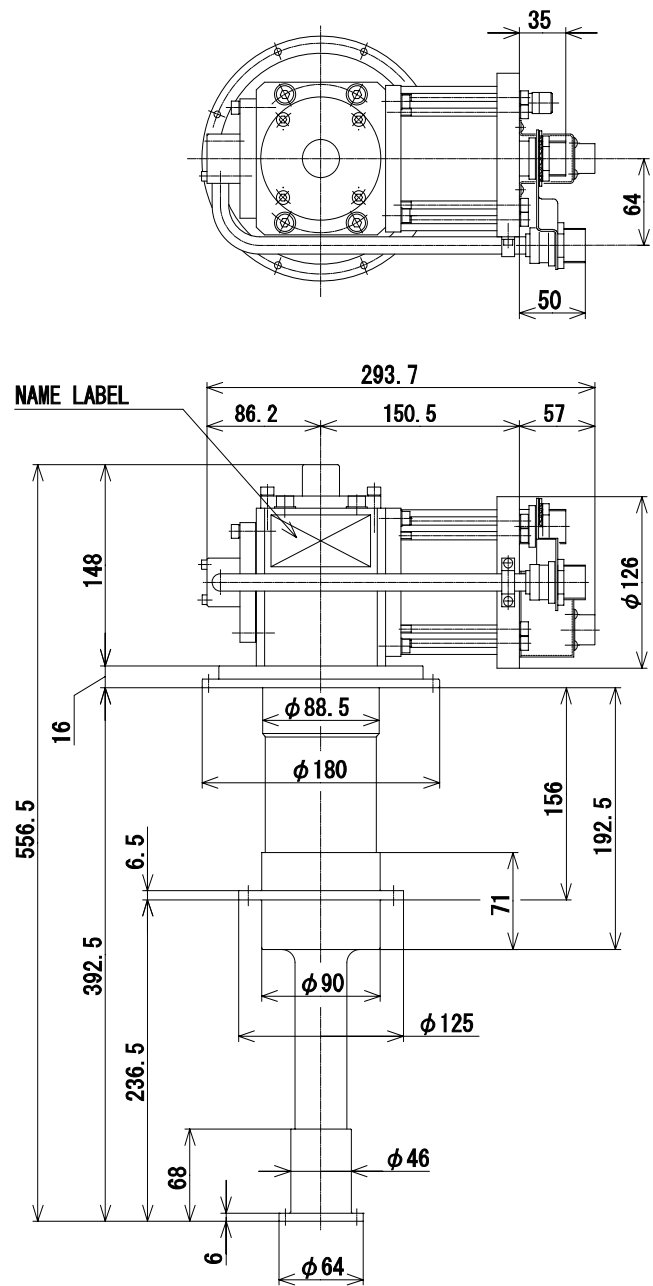

RDK-408D COLD HEAD

REVISION CONTROL

Manual No.	Revision	Remarks	Date
CD32ZZ-064	-A	Publication of first edition.	DEC. 10 / 1999
	-B	Add the CNA-61C, D Compressor Unit	OCT. 2 / 2000
	-C	Change the SHI address.	JAN. 25 / 2001
	-D	Change the division name.	JUNE 9 / 2003